

# MS-Q QUADRUS®



## Imager for Direct Part Mark Reading

The MS-Q Quadrus is the most aggressive handled imager available for decoding symbols on low contrast substrates such as metal, plastic, rubber, and glass. It is optimized to read both linear and 2D symbols that use direct part mark (DPM) methods such as dot peen and laser/chemical etch.

With custom optics and advanced decode algorithms, the MS-Q Quadrus provides the decoding power of a smart camera into a powerful handled device.

### MS-Q Quadrus: At a Glance

- Decodes/second: up to 10
- Read Range: 2 to 11.5" (51 to 292 mm)
- Patented Quadrus Technology
- Bluetooth, USB, RS232, PS2 Interface Options
- Rugged Handle Options:
  - Cabled
  - 1950 mAH
  - 3900 mAH



ESP®: Easy Setup Program software provides quick and easy setup and configuration of all Microscan readers.

For more information on this product, visit [www.quadrus-ez.com](http://www.quadrus-ez.com).

### MS-Q Quadrus: Available Codes



#### Optimized Resolution

The MS-Q Quadrus handled imager is available in a high resolution optical version which is custom designed to optimize resolution for reading small 2D symbols in direct part mark applications. Also available, a standard resolution version is suitable for reading all printed symbols, plus many directly marked symbols.

#### User-Friendly Design

All MS-Q imagers feature point-and-click targeting with a red laser spot to quickly center the symbol in the field of view. Beeper, vibrator and multipurpose performance indicators provide real time feedback.

#### Aggressive Decoding

Patented Quadrus decode algorithms provide outstanding performance on difficult low contrast or damaged 2D symbols.

#### Security Option

The secured version of the MS-Q Quadrus has disabled image capture and downloading. Permanent removal of its photographic functions allows use within sensitive industrial areas where photographic devices are prohibited.

#### System Integration

All MS-Q imagers are available in 3 configuration options including batch, cabled and wireless Bluetooth.

#### IUID Codes

The MS-Q Quadrus can read IUID codes on a variety of surfaces. Software enables IUID code format validation and constructs the IUID string for DoD suppliers.

#### Application Examples

- Automotive
- Aerospace
- Electronics
- Department of Defense suppliers

# MS-Q QUADRUS<sup>®</sup> IMAGER SPECIFICATIONS AND OPTIONS

## IMAGER MECHANICAL

**Height:** 1.3" (33 mm)  
**Width:** 1.8" (46 mm)  
**Depth:** 4.3" (109 mm)  
**Weight:** 4 oz. (113g),  
 not including cable  
**Cable Length:** 6' (1.8 m)

## HANDLE & BATTERY CHARACTERISTICS

**Cabled weight:** 4.0 oz. (113)  
**Cabled weight with imager :** 7.2 oz. (204 g)  
**With 1950 mAH battery:** 4.8 oz. (136 g)  
**With 1950 mAH battery/imager:** 8 oz. (227 g)  
**With 3900 mAH battery:** 6.4 oz. (181 g)  
**With 3900 mAH battery/imager:** 9.6 oz. (272 g)

## BATTERY BLANK HANDLE VIEW

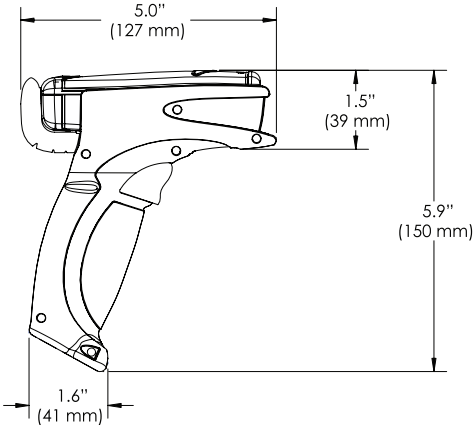

## ENVIRONMENTAL

**Operating Temperature:** 0° to 50°C (32° to 122°F)  
**Battery Blank Operating Temperature:** -35° to 50°C (-31 to 122°F)  
**Storage Temperature:** -20° to 60° C (-4 to 140°F)  
**Humidity:** 5 to 90% (non-condensing)

## CE STANDARDS

**Immunity:** EN 55024 **ESD:** EN 61000-4-2  
**Radiated RF:** EN61000-4-3 **Keyed Carrier:** ENV50204 **EFT:** EN61000-4-4 **Conducted RF:** EN61000-4-6,  
**Emissions:** EN55022, Class B Radiated, Class B Conducted

## LIGHT COLLECTION OPTIONS

**Sensor:** CMOS, progressive scan, 1.33 MP (1024 by 1280), 256 gray scale

### Sensor Array:

Near Field: 1024 by 640 (default)  
 Far Field: 1024 by 640 (default)

### Standard Resolution Field of View:

Near: 21.5° horizontal by 16.2° vertical  
 Far: 22.9° horizontal by 11.6° vertical

### High Resolution Field of View:

Near & Far: 21° horizontal by 13° vertical

### Standard Resolution Focal Point:

Near: 4" (101.6 mm) Far: 9" (228.6 mm)

### High Resolution Focal Point:

Near: 2.75" (70 mm) Far: 4.5" (115 mm)



## SYMBOLGY TYPES

**Linear Bar Codes:** Code 39, Code 128, I2 of 5, GS1 Databar (RSS), UPC/EAN, Codabar, Codablock F, Code 93, PLANET, PostNet, KIX Code, Postal Codes  
**Stacked Symbolgies:** PDF417, Micro PDF417  
**2D Symbolgies:** Data Matrix, MaxiCode, Aztec Code, QR Code, Micro QR Code

## READ PARAMETERS

**Pitch:** ±60° (front to back) **Skew:** ±60° **Tilt:** 360°  
**Focal Range:** 1 to 11.5" (25 to 292 mm)  
**Rotational Tolerance:** ±180°

## NEAR/FAR FIELD FOCAL DISTANCE COMPARISON CHART

### MEASUREMENT

Shown in inches (mm)

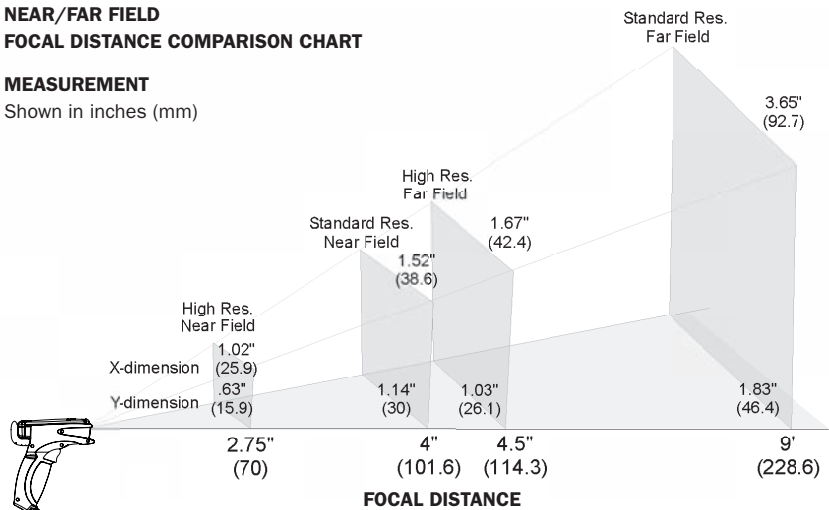

## READ RANGES, STANDARD RESOLUTION

Narrow Bar-Width	Read Range Distance
.0075" (.191 mm)	3.2 to 3.9" (81 to 99 mm)
.015" (.381 mm)	3.0 to 9.0" (76 to 229 mm)
.020" (.508 mm)	3.0 to 11.5" (76 to 292 mm)

## READ RANGES, HIGH RESOLUTION

Narrow Bar-Width	Read Range Distance
.005" (.127 mm)	1.75 to 2.5" (44.4 to 63.5 mm)
.0075" (.191 mm)	1.75 to 4" (44.4 to 101.6 mm)
.010" (.254 mm)	1.75 to 4.75" (44.4 to 102.6 mm)
.015" (.381 mm)	1.75 to 6" (44.4 to 152.3 mm)
.020" (.508 mm)	1.75 to 6.5" (44.4 to 165.1 mm)

**Print Contrast Resolution:** 25 percent (bar codes); 35 percent (PDF417); absolute dark/light reflectance differential, measure at 650 nm.  
**Target Beam:** Visible Laser Diode at 630 nm. Class 2  
**Ambient Light Immunity:** Sunlight: Up to 9,000 ft-candles 96,890 lux **Shock:** Withstands 100+ drops of 6.5" (2 meters) to concrete

## INDICATORS

**LED Indicators:** Memory status, Battery power, Successful decode, and Connection status  
**Programmable Indicators:** Beeper or Vibrate option; communicates scanner operation and communication functions to user

## IMAGE OUTPUT OPTIONS

**Format:** Jpeg, Raw (uncompressed)

## COMMUNICATION PROTOCOLS

**Standard Interface:** USB **Optional Interface:** RS-232, Bluetooth Class 1 Radio at 328' (100 m), PS2

## ELECTRICAL

**Power Requirements:** 5 VDC (mA)  
**Typical:** 140 **Peak:** 310 **Idle:** NA/  
**Bluetooth Radio at 295' (90 m) away (mA):**  
**Typical:** 280 **Peak:** 350 **Idle:** 96 **Sleep:** 3  
**Bluetooth Radio at 33' (10 m) away (mA):**  
**Typical:** 260 **Peak:** 350 **Idle:** 96 **Sleep:** 3  
**Life of 1950 mAH Battery with Radio:** Will support 4000 read/transmits per charge including 8 hours of standby interval.  
**Life of 3900 mAH Battery with Radio:** Will support 8000 read/transmits per charge including 16 hours of standby interval.  
**Batch Memory:** Minimum of 1MB

## SAFETY CERTIFICATIONS FCC, CE

## ISO CERTIFICATION

Issued by TÜV USA Inc, Member of TÜV NORD Group, Cert No. 06-1080



ISO 9001:2000  
**Certified QMS**

## FIELD OF VIEW, STANDARD RESOLUTION

Near Field of View	
Distance	Field of View Size
4" (101.6)	1.52 x 1.14" (38.6 x 30 mm)
Far Field of View	
9" (228.6)	3.65 x 1.83" (92.7 x 46.4 mm)

## FIELD OF VIEW, HIGH RESOLUTION

Near Field of View	
Distance	Field of View Size
2" (50.8)	.74 x .46" (18.8 x 11.6 mm)
2.5" (63.5)	.93 x .57" (23.5 x 14.5 mm)
2.75" (69.9)	1.02 x .63" (25.9 x 15.9 mm)
3" (76.2)	1.11 x .68" (28.3 x 17.4 mm)
3.5" (88.9)	1.3 x .80" (33 x 20.3 mm)
4" (101.6)	1.48 x .91" (37.7 x 23.2 mm)
Far Field of View	
2" (50.8)	.74 x .46" (18.8 x 11.6 mm)
2.5" (63.5)	.93 x .57" (23.5 x 14.5 mm)
3" (76.2)	1.11 x .68" (28.2 x 17.4 mm)
3.5" (88.9)	1.3 x .80" (32.9 x 20.3 mm)
4" (101.6)	1.48 x .91" (37.6 x 23.2 mm)
4.5" (114.3)	1.67 x 1.03" (42.4 x 26.1 mm)
5" (127)	1.85 x 1.14" (47.1 x 28.9 mm)
5.5" (139.7)	2.04 x 1.25" (51.8 x 31.8 mm)
6" (152.7)	2.22 x 1.37" (56.5 x 34.7 mm)
6.5" (165.1)	2.41 x 1.48" (61.2 x 37.6 mm)

## ROHS/WEEE COMPLIANT



©2008 Microscan Systems, Inc. SP013D 09/08  
 Read Range and other performance data is determined using high quality Grade A symbols per ISO/IEC 15415 and ISO/IEC 15416 in a 25°C environment. For application-specific Read Range results, testing should be performed with symbols used in the actual application. Microscan Applications Engineering is available to assist with evaluations. Results may vary depending on symbol quality. **Warranty-** One year limited warranty on parts and labor. Extended warranty available.

# MICROSCAN<sup>®</sup>

**Microscan Systems, Inc.**  
 Tel 425 226 5700 / 800 251 7711  
 Fax 425 226 8250

**Microscan Europe**  
 Tel 31 172 423360 / Fax 31 172 423366

**Microscan Asia Pacific R.O.**  
 Tel 65 6846 1214 / Fax 65 6846 4641

Part of a full range of sales tools available from our website:

**www.microscan.com**  
**E-mail:** info@microscan.com  
**Tech Support:** helpdesk@microscan.com